

**SERVICE REPAIR**

**MANUAL**

Hyster G007 (H170HD, H280HD) Forklift

***HYSTER***

# **ALTERNATOR WITH REGULATOR**

**DELCO, MOTOROLA, AND  
LEECE-NEVILLE**

**COVERS DELCO, MOTOROLA, AND  
LEECE-NEVILLE ALTERNATORS USED  
ON HYSTER LIFT TRUCKS**

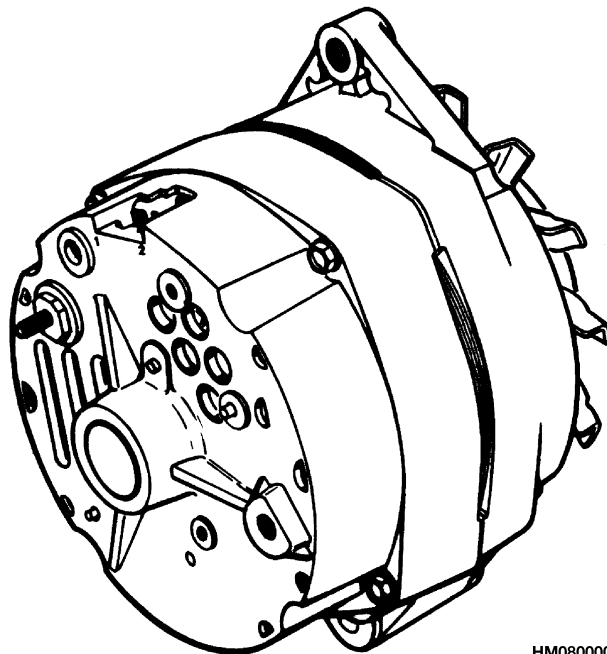

HM080000

# ***HYSTER***

# SAFETY PRECAUTIONS

## MAINTENANCE AND REPAIR

- When lifting parts or assemblies, make sure all slings, chains, or cables are correctly fastened, and that the load being lifted is balanced. Make sure the crane, cables, and chains have the capacity to support the weight of the load.
- Do not lift heavy parts by hand, use a lifting mechanism.
- Wear safety glasses.
- **DISCONNECT THE BATTERY CONNECTOR** before doing any maintenance or repair on electric lift trucks.
- Disconnect the battery ground cable on internal combustion lift trucks.
- Always use correct blocks to prevent the unit from rolling or falling. See **HOW TO PUT THE LIFT TRUCK ON BLOCKS** in the **Operating Manual** or the **Periodic Maintenance** section.
- Keep the unit clean and the working area clean and orderly.
- Use the correct tools for the job.
- Keep the tools clean and in good condition.
- Always use **HYSTER APPROVED** parts when making repairs. Replacement parts must meet or exceed the specifications of the original equipment manufacturer.
- Make sure all nuts, bolts, snap rings, and other fastening devices are removed before using force to remove parts.
- Always fasten a **DO NOT OPERATE** tag to the controls of the unit when making repairs, or if the unit needs repairs.
- Be sure to follow the **WARNING** and **CAUTION** notes in the instructions.
- Gasoline, Liquid Petroleum Gas (LPG), Compressed Natural Gas (CNG), and Diesel fuel are flammable. Be sure to follow the necessary safety precautions when handling these fuels and when working on these fuel systems.
- Batteries generate flammable gas when they are being charged. Keep fire and sparks away from the area. Make sure the area is well ventilated.

**NOTE:** The following symbols and words indicate safety information in this manual:



### **WARNING**

**Indicates a condition that can cause immediate death or injury!**



### **CAUTION**

**Indicates a condition that can cause property damage!**

## TABLE OF CONTENTS

General .....	1
Description .....	1
Alternator Repair .....	3
Alternator Type A .....	3
Remove and Disassemble.....	3
Clean .....	4
Assemble .....	5
Install .....	5
Alternator Type B .....	8
Remove and Disassemble.....	8
Clean .....	8
Assemble .....	9
Install .....	10
General Check and Adjustment .....	11
Low Output Check (Type A or Type B) .....	11
High Output Check (Type A or Type B) .....	13
Brushes Circuit Check .....	14
Delco Alternators .....	14
Motorola Alternators .....	15
Diodes Check .....	16
Diode Bridge Check .....	16
Delco and Leece-Neville Alternators .....	16
Motorola Alternators .....	16
Rotor Field Winding Check .....	17
Stator Windings Check .....	18
Voltage Regulator Check .....	18
Troubleshooting.....	18

This section is for the following models:

Covers Delco, Motorola, and Leece-Neville alternators used  
on Hyster lift trucks

**Thanks very much for your reading,  
Want to get more information,  
Please click here, Then get the complete  
manual**

**JustClickHere** 

**NOTE:**

**If there is no response to click on the link above,  
please download the PDF document first, and then  
click on it.**

**Have any questions please write to me:  
[admin@servicemanualperfect.com](mailto:admin@servicemanualperfect.com)**

**"THE  
QUALITY  
KEEPERS"**

**HYSTER  
APPROVED  
PARTS**

## General



### CAUTION

When using an arc welder, always disconnect the ground lead from the lift truck battery to prevent alternator or battery damage. Attach the welding ground clamp as close to the weld area as possible to prevent welding current from damaging the bearings.

The diodes and resistors in the electrical system can be damaged if the following cautions are not followed:

- Do not disconnect the battery when the engine is running. The voltage surge can damage the diodes and resistors in the electrical system.
- Do not disconnect an electric wire before the engine is stopped and the switches are OFF.

- Do not cause a short circuit by connecting the electric wires to the wrong terminals. Make sure a correct identification is made of the wire before it is connected.
- Make sure a battery is the correct voltage and polarity before it is connected.
- Do not check for current flow by making a spark because the electronic components can be damaged.

**NOTE:** Information on alternators manufactured outside the United States is in the SRM (Service Repair Manual) sections for lift trucks that use those alternators.

This section has a description and the repair procedures for the alternator with a voltage regulator as part of the alternator.

## Description

**NOTE:** For this SRM section, the alternators are in two groups: Type A and Type B. The two types are very similar, but the Type A alternators have a set of three diodes (diode set) as well as the diode bridge. The Type B alternator has zener diodes as part of the diodes in the diode bridge. This alternator does not have a diode set, but does have an additional fan inside the rear housing. The basic operation of both types is very similar.

The alternator generates an alternating current when the engine is running. The alternator is either **ON** or **OFF**. The alternator generates maximum current when it is **ON** and no current when it is **OFF**. The regulator switches the alternator between **ON** and **OFF** to get the average current needed to charge the battery. Alternator output is directly changed by engine speed and rotor field current. The alternating current is changed to a direct current by the diode bridge inside the alternator.

The alternator has these parts (see Figure 1 and Figure 2):

- A stator
- A rotor
- A diode bridge
- A diode set (Type A only)
- Two end housings or frame halves
- A solid-state voltage regulator

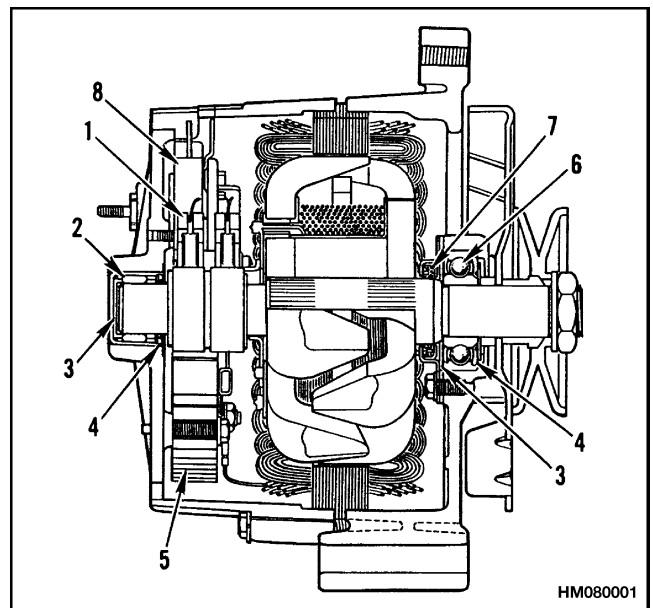

**NOTE:** DELCO TYPE A SHOWN.

- |                     |                  |
|---------------------|------------------|
| 1. BRUSH ASSEMBLY   | 5. DIODE BRIDGE  |
| 2. ROLLER BEARING   | 6. BALL BEARINGS |
| 3. GREASE RESERVOIR | 7. FELT SEAL     |
| 4. LIP SEAL         | 8. REGULATOR     |

*Figure 1. Alternator Cross Section*

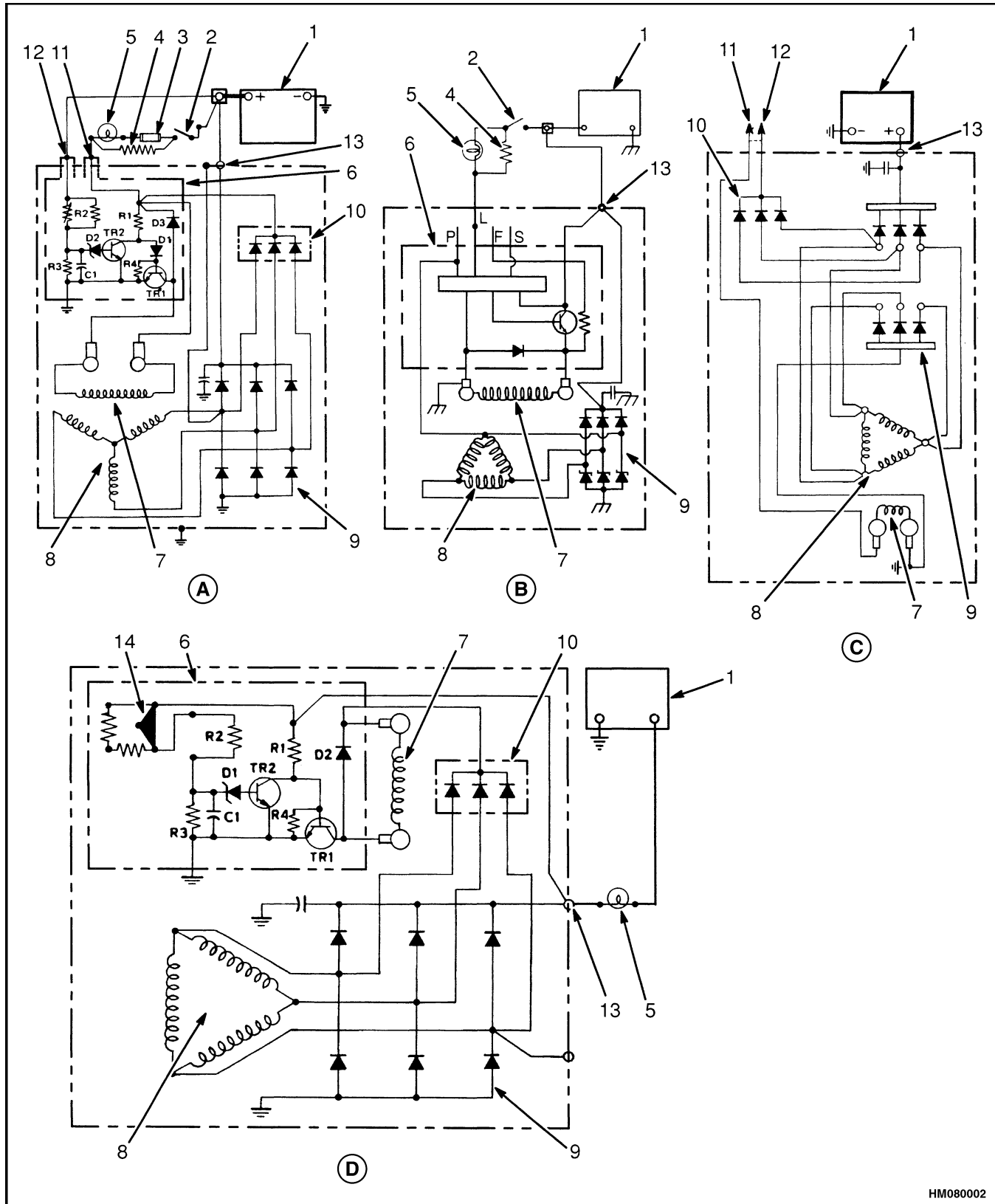

HM080002

Figure 2. Alternator Schematics



*Legend for Figure 2*

**NOTE:** LEECE-NEVILLE NOT AVAILABLE, SIMILAR TO THOSE SHOWN.

- |  |   |
|--|---|
| <p><b>A.</b> DELCO TYPE A (SMALL CAPACITY LIFT TRUCKS)</p> <p><b>B.</b> DELCO TYPE B</p> <p>1. BATTERY</p> <p>2. KEY SWITCH</p> <p>3. FUSE</p> <p>4. RESISTOR</p> <p>5. INDICATOR LIGHT OR AMMETER</p> <p>6. VOLTAGE REGULATOR</p> <p>7. ROTOR FIELD</p> | <p><b>C.</b> MOTOROLA TYPE A</p> <p><b>D.</b> DELCO TYPE A (LARGE CAPACITY LIFT TRUCKS)</p> <p>8. STATOR</p> <p>9. DIODE BRIDGE</p> <p>10. DIODE SET</p> <p>11. FIELD TERMINAL</p> <p>12. REGULATOR TERMINAL</p> <p>13. OUTPUT (BAT) TERMINAL</p> <p>14. VOLTAGE ADJUSTMENT</p> |
|--|---|

The direct current from the diodes of the diode bridge flows to the output or BAT terminal. A capacitor between the BAT terminal and the electrical ground removes any remaining alternating current from the direct current. The capacitor also protects the diodes from high voltages. The voltage is controlled by the amount of current flowing through the field winding in the alternator and the rpm of the rotor. The voltage regulator, inside the housing, contains a transistor, diodes, resistors, and capacitor. The voltage regulator cannot be repaired.

**NOTE:** On some large capacity lift trucks, the alternator has an external voltage adjustment.

The voltage regulator controls the alternator to charge the battery. The voltage is set by the manufacturer and is not usually adjustable. Battery voltage decreases as the starting circuit and other circuits take energy from the battery. When the key switch is put in the **IGN** position, the voltage regulator is energized. A positive current flows to the field terminal (F or 1) on Type A alternators and (L) on Type B alternators. The battery sends a positive current to the regulator terminal (Type A R or 2) and the BAT terminal. The regulator senses a decrease in battery voltage and increases the alternator output to charge the battery.

## Alternator Repair

### ALTERNATOR TYPE A

#### Remove and Disassemble



#### **WARNING**

**Always disconnect the battery ground cable before making repairs to prevent possible damage and injury. Install a tag on the battery terminal so that no one connects the cable on the terminal.**

**NOTE:** Use Troubleshooting and General Check and Adjustment, Low Output Check (Type A or Type B), High Output Check (Type A or Type B), Brushes Circuit Check, Diodes Check, Diode Bridge Check, Rotor Field Winding Check, Stator Windings Check, and Voltage Regulator Check procedures of this SRM before starting any repair procedures. Make sure that repair or replacement of that part is necessary before removal, disassembly, or replacement of the part.

**NOTE:** There are some checks of the alternator that are done with the alternator on the engine. See General Check and Adjustment, Low Output Check (Type A or Type B), High Output Check (Type A or Type B), Brushes Circuit Check, Diodes Check, Diode Bridge Check, Rotor Field Winding Check, Stator Windings Check, and Voltage Regulator Check procedures of this SRM before starting any removal or repair procedures.

**NOTE:** Many parts of the Leece-Neville alternator can be replaced without disassembling the alternator. See Figure 5. The alternator must be disassembled to replace only the diode bridge, filter capacitor, rotor, stator, or bearings.

1. Disconnect the battery ground cable. See Figure 3, Figure 4, and Figure 5. Install labels and disconnect the wires at the alternator. Loosen the alternator mount capscrews and remove the drive belt. Remove the capscrews that hold the alternator to the engine.

2. On Leece-Neville alternators, remove the brushes, voltage regulator, or diode set. Install labels on all wires for correct connection during installation.
3. Put a mark on each housing and on the stator for correct alignment during assembly. Remove the bolts that hold the housings together. Separate the housings and stator.
4. Put the rotor in a vise that has soft jaws. Do not tighten the vise to cause rotor distortion. Use a socket wrench to remove the pulley nut. Remove the pulley, fan, collar, spacer, shield, or other parts between the fan and housing. Remove the front housing from the rotor.
5. Remove any nuts or screws that fasten parts inside to the rear housing. Then, remove the stator assembly from the rear housing so that the other parts can be removed. Remove the screws for the capacitor, diode bridge, diode set, brushes, and other parts as necessary. If the stator will be removed from the diode bridge, make sure the wires have tags for correct connection during assembly.
6. Mark the stator to show the position of the brushes and connector or diode bridge assembly. Use pliers as a heat sink to keep heat from the

diodes. Use a soldering iron to remove the stator leads from the diode assembly.

7. Remove the bearings from the housings only if they will be replaced.

**Clean**

**WARNING**

Compressed air can move particles so that they cause injury to the user or to other personnel. Make sure that the path of the compressed air is away from all personnel. Wear protective goggles or a face shield to prevent injury to the eyes.

**CAUTION**

Never use solvent on the parts of the alternator.

**NOTE:** If necessary, use fine abrasive cloth to polish the slip rings. The abrasive cloth must be number 500 to 600. Remove all dust. Turn the rotor while polishing the slip rings.

Use compressed air to remove dirt from the alternator. Clean the brushes and slip rings with a clean, dry cloth.

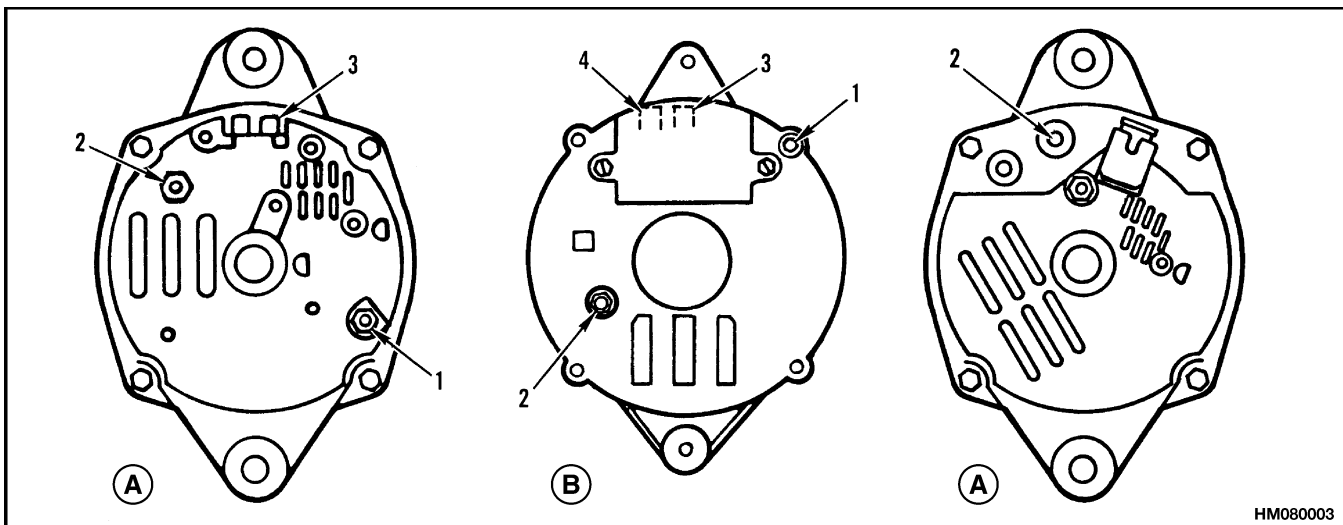

HM080003

A. DELCO

B. MOTOROLA

1. GROUND TERMINAL
2. BATTERY TERMINAL (BAT OR +)

3. FIELD TERMINAL
4. REGULATOR TERMINAL

**Figure 3. Type A Alternators, Rear Views**

## Assemble

1. For Delco (Type A) alternators, install a new bearing(s) in the housing as follows (see Figure 3, Figure 4, and Figure 5):
  - a. Install a new plug and seal in the rear housing. Push the bearing from the outside of the housing until the top of the bearing is even with the outside of the housing. Hold the housing with the collar on the inside of the housing. Keep the lip of the seal away from the bearing. Lubricate the bearing area with non-conductive grease.
  - b. Install a new bearing in the front housing. Fill one quarter of the grease reservoir with non-conductive grease. Move the grease so that it touches the bearing when the retainer plate is installed.
  - c. Add the same type of grease to fill the area between the retainer plate and the bearing. Install the spacer, gasket, and retainer plate on the bearing. Fasten the retainer plate in position with the three screws and lockwashers.
2. For Motorola and Leece-Neville alternators, use a press to install the rear bearing on the rotor. Install the bearing and bearing retainer in the front housing. If used, install the spacer on the bearing.



### CAUTION

**Hold the rotor in a vise that has soft jaws. Do not tighten the vise more than necessary.**

3. Install the front housing on the rotor. If used, install the spacer or shield, shaft key, and washer. Install the fan, pulley, lockwasher, and nut. Tighten the nut to 54 to 81 N•m (40 to 60 lbf ft).



### CAUTION

**Be sure to install the insulators. Make sure the heat sink does not touch the housing.**

4. Install the diode bridge and heat sink in the reverse order of disassembly. Make sure the insulators and washers are in the correct positions. Install the capacitor.
5. On Delco alternators, install parts as follows:

- a. Install the brush and holder, voltage regulator, and diodes from the inside of the alternator. Make sure the insulator sleeves are on the screws for the brush holder. Install the capacitor.
  - b. Install the stator in the rear housing. Connect the three wires from the stator to the diode bridge and fasten at the studs. Connect the wires from the diodes to the studs on the diode bridge. Install and tighten the three lockwashers and nuts.
  - c. Install the brushes in the brush holders. To hold the brushes in position, put a pin through the hole in the brush holders. Apply a thin layer of oil to the lip of the seal for the bearing.
6. On Motorola alternators, install parts as follows:
    - a. Install the diode bridge on the stator. Use pliers to keep the heat from the soldering iron away from the diodes.
    - b. Install the capacitor, diode set, and terminal on the diode bridge. Align the marks made during removal and install the stator and bridge assembly in the rear housing.
  7. Align the marks made during disassembly. Carefully install the stator and the rear housing over the rotor. Do not damage the seal while sliding the housing over the rotor shaft. Install the front housing.
  8. Install the four screws to hold the alternator together. On Delco alternators, remove pin to release the brushes.
  9. On Motorola alternators, install the brush holder and brushes. Make sure the washer is on the right-hand screw. Install the voltage regulator and tighten the screws.
  10. On Leece-Neville alternators, install the brushes, voltage regulator, or diode set in the reverse order of removal.

## Install

1. Install the alternator in the bracket on the engine and adjust the tension of the belt.

2. Connect all wires and the connector according to the labels made during removal. Also see the schematic diagram for your alternator in Figure 2. Make sure all wires are connected correctly and all fasteners are tight. See Figure 3.
3. Check the indicator light or the ammeter to check the operation of the alternator. The indicator light for Type A alternators will only be ON if the battery is discharged.

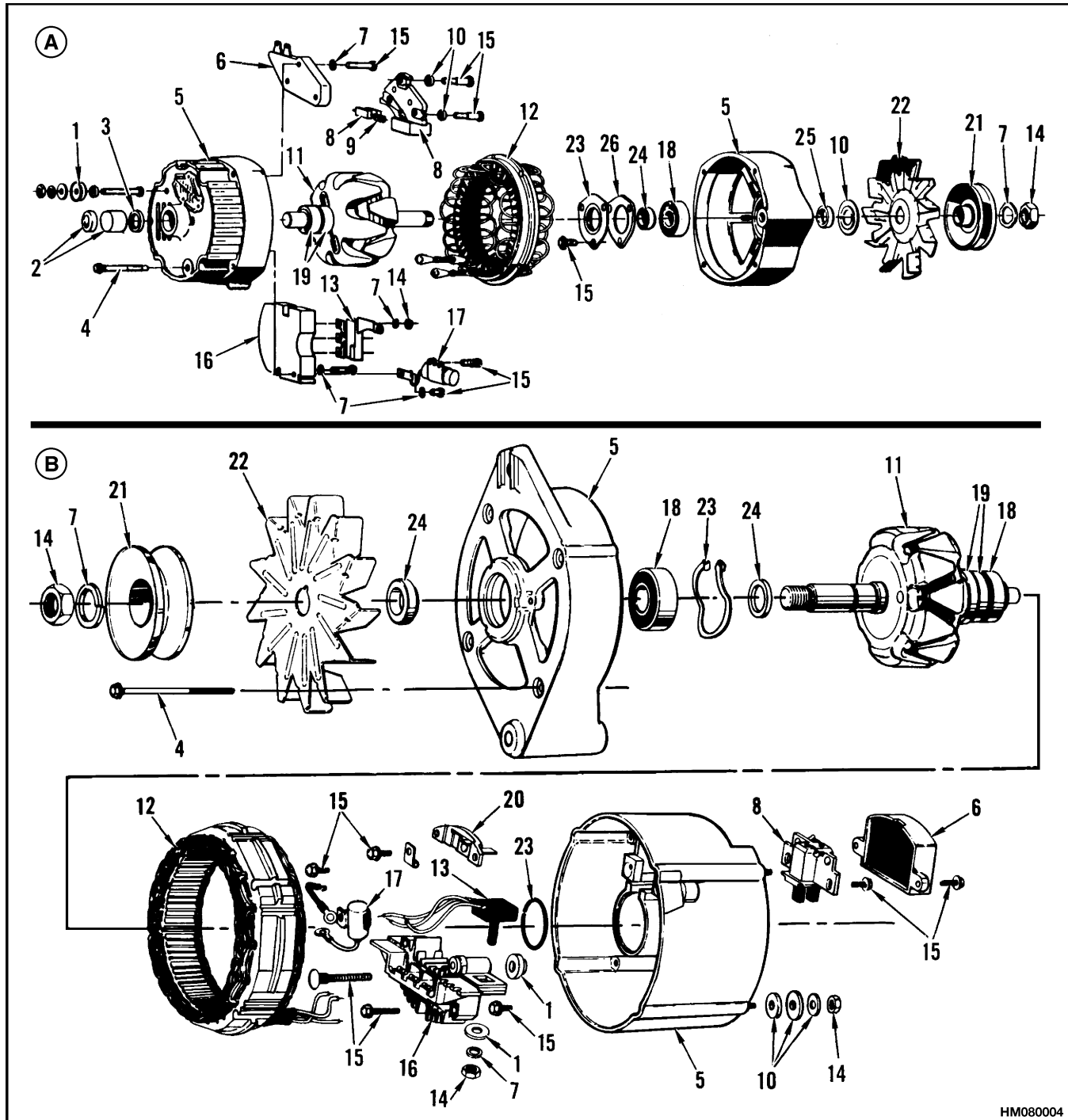

HM080004

Figure 4. Type A Alternators, Exploded Views

*Legend for Figure 4*

**A. DELCO**

- 1. INSULATOR
- 2. PLUG AND BEARING
- 3. BEARING SEAL
- 4. BOLT
- 5. HOUSING
- 6. VOLTAGE REGULATOR
- 7. LOCKWASHER
- 8. BRUSH AND HOLDER
- 9. BRUSH SPRING
- 10. WASHER
- 11. ROTOR
- 12. STATOR
- 13. DIODES

**B. MOTOROLA**

- 14. NUT
- 15. SCREW
- 16. DIODE BRIDGE
- 17. CAPACITOR
- 18. BEARING
- 19. SLIP RINGS
- 20. TERMINAL
- 21. PULLEY
- 22. FAN
- 23. RETAINER
- 24. SPACER
- 25. SHIELD
- 26. GASKET

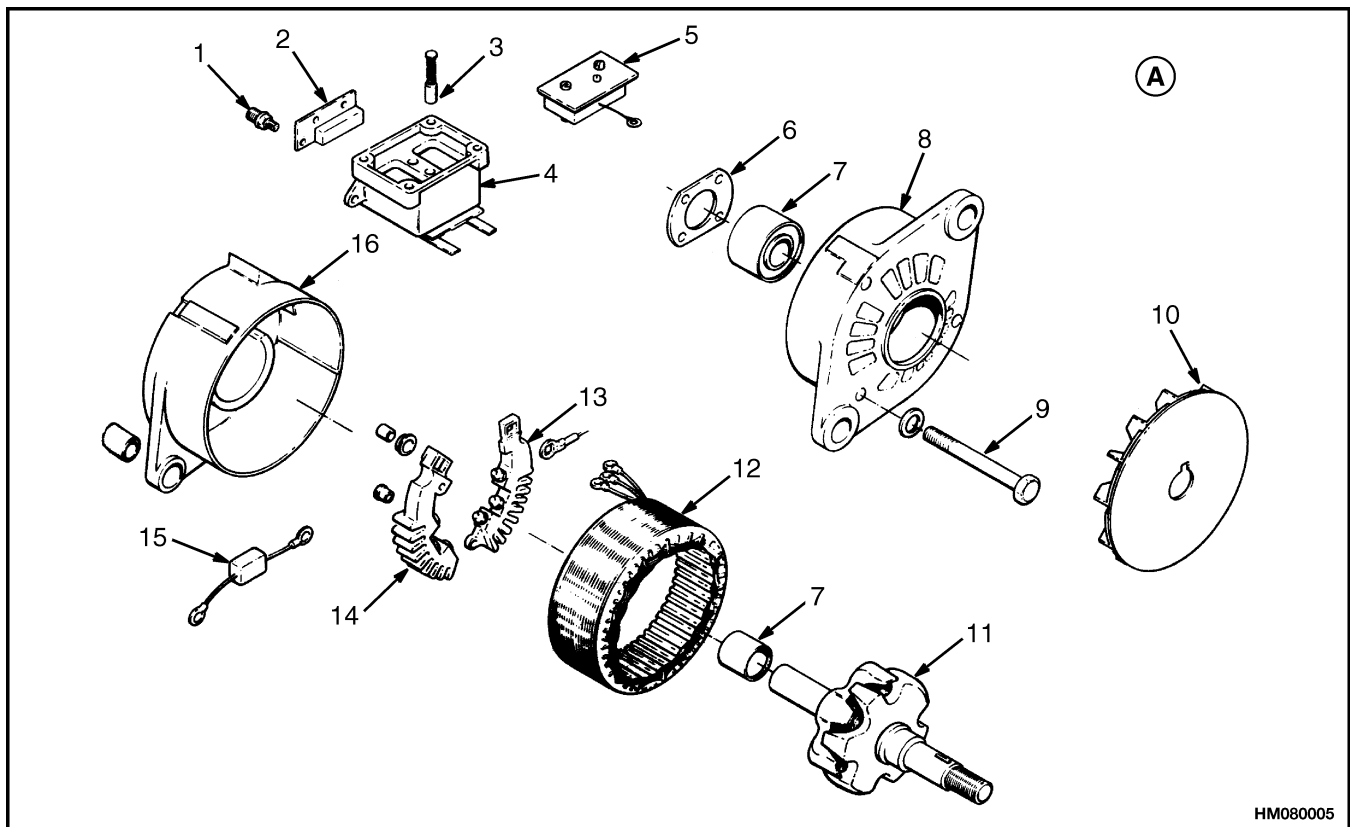

HM080005

**A. LEECE-NEVILLE**

- 1. TERMINAL
- 2. DIODE SET
- 3. BRUSH AND SPRING
- 4. BRUSH HOLDER
- 5. VOLTAGE REGULATOR
- 6. BEARING RETAINER
- 7. BEARING
- 8. FRONT HOUSING

- 9. BOLT
- 10. FAN
- 11. ROTOR
- 12. STATOR
- 13. NEGATIVE DIODE BRIDGE
- 14. POSITIVE DIODE BRIDGE
- 15. FILTER CAPACITOR
- 16. REAR HOUSING

*Figure 5. Type A Alternator; Exploded View*

## ALTERNATOR TYPE B

### Remove and Disassemble

 **WARNING**

**Always disconnect the battery ground cable before making repairs to prevent possible damage and injury. Install a tag on the battery terminal so that no one connects the cable on the terminal.**

**NOTE:** Use the Troubleshooting and General Check and Adjustment, Low Output Check (Type A or Type B), High Output Check (Type A or Type B), Brushes Circuit Check, Diodes Check, Diode Bridge Check, Rotor Field Winding Check, Stator Windings Check, and Voltage Regulator Check procedures of this SRM before starting any repair procedures. Make sure that repair or replacement of that part is necessary before removal, disassembly, or replacement of the part.

**NOTE:** There are some checks of the alternator that are done with the alternator on the engine. See General Check and Adjustment, Low Output Check (Type A or Type B), High Output Check (Type A or Type B), Brushes Circuit Check, Diodes Check, Diode Bridge Check, Rotor Field Winding Check, Stator Windings Check, and Voltage Regulator Check procedures of this SRM before starting any removal or repair procedures.

1. Disconnect the battery ground cable. See Figure 6, Figure 7, and Figure 8. Install labels and disconnect the wires at the alternator. Disconnect the wire connector. Loosen the alternator mount capscrews and remove the drive belt. Remove the capscrews that hold the alternator to the engine.
2. Put a mark on each housing and on the stator for correct alignment during assembly. Remove the bolts that hold the housings together. Separate the housings and stator.
3. Put the rotor in a vise that has soft jaws. Do not tighten the vise to cause rotor distortion. Use a socket wrench to remove the pulley nut. Remove the pulley, collar, fan, outside collar, front housing, and inside collar from the rotor.

**NOTE:** The cover must be replaced if the parts will be removed from the stator. If necessary, remove the stator as described in Step 4 and Step 5.

4. Use a punch to remove the rivets or pins that fasten the cover. Remove the cover for access to the stator leads. Discard the cover. See Figure 7.
5. Cut the stator leads as close to the connectors as possible. Install labels on the leads for correct connection during assembly and remove the stator from the rear housing.
6. Use a punch to remove the three baffle pins and remove the baffle. See Figure 7.

**NOTE:** Carefully make a note of the sequence of removal of parts in Step 7 and Step 8 for correct installation. Also make a note of all types of connections (crimp, soldered, or welded) as well as all mechanical fasteners.

7. Remove the three mount screws and "BAT" terminal nut. See Figure 8. Lift the brush holder, voltage regulator, and diode bridge from the housing.
8. Open the crimps or use a soldering iron and disconnect the connectors to separate the brush holder, voltage regulator, and diode bridge.
9. If the bearing will be replaced in the rear housing, remove the bearing and retainer ring.

### Clean

 **WARNING**

**Compressed air can move particles so that they cause injury to the user or to other personnel. Make sure that the path of the compressed air is away from all personnel. Wear protective goggles or a face shield to prevent injury to the eyes.**

 **CAUTION**

**Never use solvent on the parts of the alternator.**

**NOTE:** If necessary, use fine abrasive cloth to polish the slip rings. The abrasive cloth must be number 500 to 600. Remove all dust. Turn the rotor while polishing the slip rings.

Use compressed air to remove dirt from the alternator. Clean the brushes and slip rings with a clean, dry cloth.

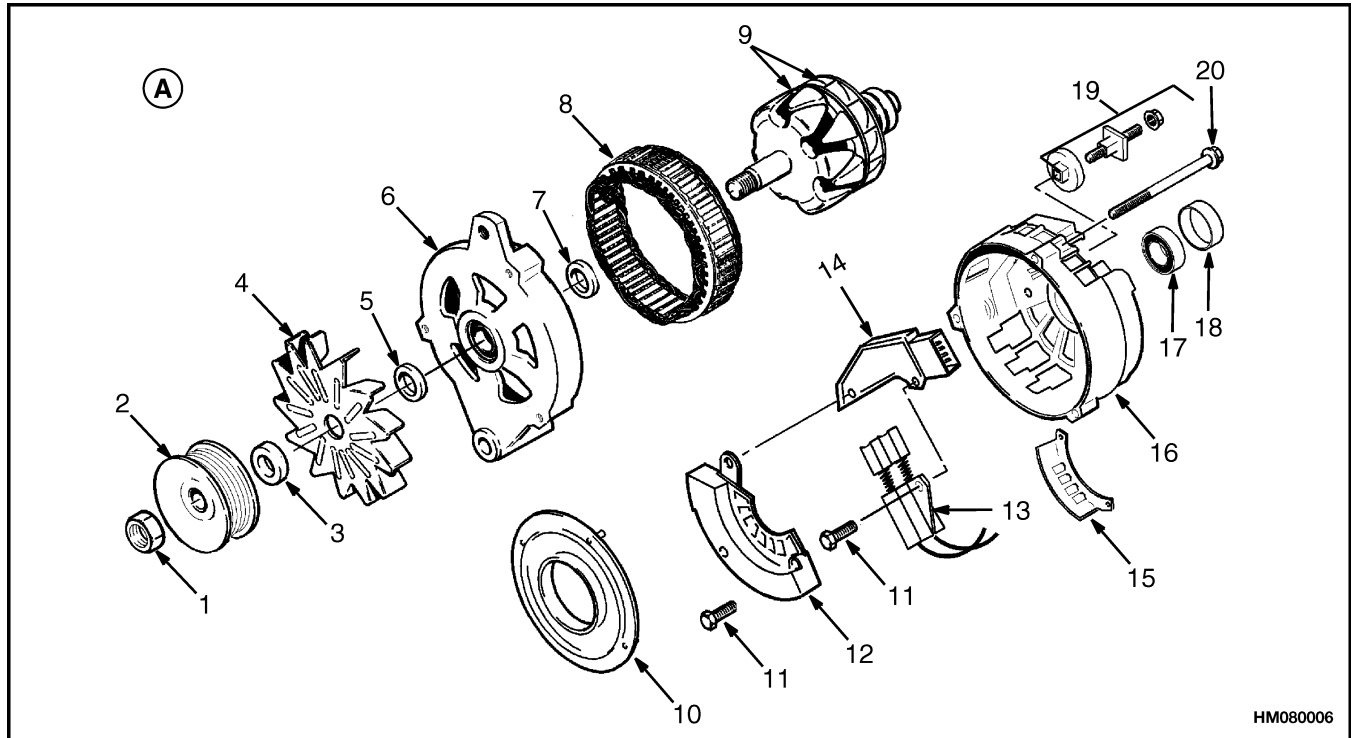

HM080006

**A. DELCO**

- |                   |                        |                   |
|-------------------|------------------------|-------------------|
| 1. NUT            | 8. STATOR              | 15. COVER         |
| 2. PULLEY         | 9. ROTOR AND FAN       | 16. REAR HOUSING  |
| 3. COLLAR         | 10. BAFFLE             | 17. BALL BEARING  |
| 4. OUTSIDE FAN    | 11. SCREW              | 18. RETAINER RING |
| 5. OUTSIDE COLLAR | 12. DIODE BRIDGE       | 19. TERMINAL SET  |
| 6. FRONT HOUSING  | 13. BRUSHES AND HOLDER | 20. BOLT          |
| 7. INSIDE COLLAR  | 14. VOLTAGE REGULATOR  |                   |

**Figure 6. Type B Alternator, Exploded View****Assemble**

1. If the bearing was removed from the rear housing, install a new retainer ring. See Figure 6.

**CAUTION**

**The bearing is not completely installed until Step 11 is complete.**

2. Install a new bearing by pushing on the new bearing outer race until the bearing hits the bottom in the rear housing.
3. Assemble the voltage regulator, diode bridge, and brush holder on a flat surface. Put crimps in the connectors or solder the connectors to fasten and connect the parts as originally assembled. Use a pin to hold the brushes in the brush holder.
4. Put a thin coating of silicon grease on the inside of the rear housing under the diode bridge.
5. Install the bridge, regulator, and brush holder assembly in the rear housing and install the screws as removed during disassembly.
6. Install the baffle and use a punch to fasten the pins.
7. Align the marks made during disassembly and install the stator in the rear housing. Use pliers on the connectors of the diode bridge to keep heat from the diodes. Use a soldering iron to connect the stator leads to the connectors.

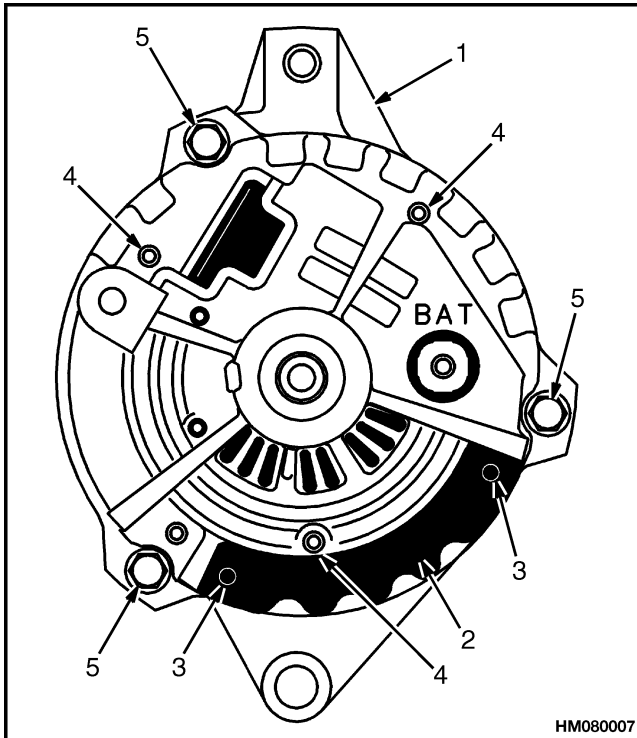

**NOTE:** TYPE B ONLY.

- |                         |                                      |
|-------------------------|--------------------------------------|
| 1. REAR HOUSING         | 4. BAFFLE PINS                       |
| 2. COVER                | 5. BOLTS TO FASTEN HOUSINGS TOGETHER |
| 3. COVER RIVETS OR PINS |                                      |

**Figure 7. Outside Rear Housing**

8. Install a new cover using rivets or pins to fasten the cover to the rear housing.
9. If necessary, install the bearing in the front housing. Put the rotor in a vise with soft jaws and install the inner collar, front housing, outer collar, fan, collar pulley, and nut on the rotor. Tighten the nut to 54 to 108 N•m (40 to 80 lbf ft).
10. Align the front and rear housings using the marks made during disassembly. Push on both the inner and outer races of the rear bearing to push the two housings and stator together. Install the three bolts that fasten the alternator together.
11. Push on both the inner and outer race of the rear bearing so that the outer race is 1.9 to 2.2 mm

(0.075 to 0.087 in.) below the surface of the rear housing.

**Install**

1. Install the alternator in the bracket on the engine and adjust the tension of the belt.
2. Connect all wires and the connector according to the labels made during removal. Also see the schematic diagram for your alternator in Figure 2. Make sure all wires are connected correctly and all fasteners are tight. See Figure 7.
3. Check the indicator light or the ammeter to check the operation of the alternator. The indicator light can also be ON if the alternator output is too high on Type B alternators.

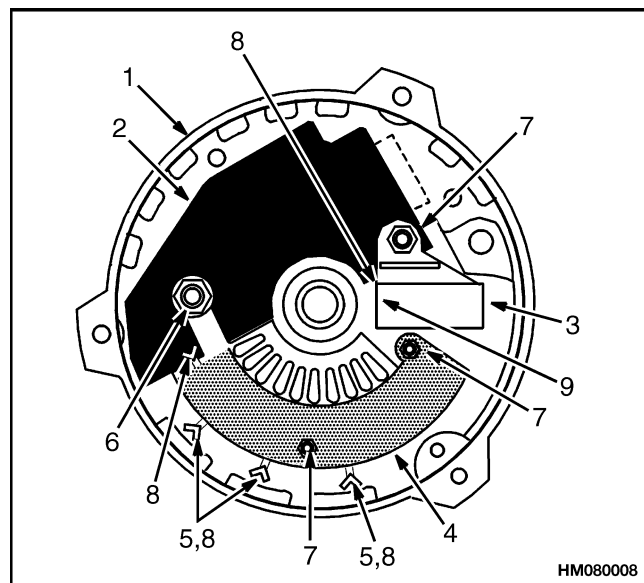

**NOTE:** TYPE B ONLY.

- |                               |                                 |
|-------------------------------|---------------------------------|
| 1. REAR HOUSING               | 6. NUT ON "BAT" TERMINAL        |
| 2. VOLTAGE REGULATOR          | 7. MOUNT SCREWS                 |
| 3. BRUSH HOLDER               | 8. SOLDERED OR WELDED CONNECTOR |
| 4. DIODE BRIDGE               | 9. BRUSH PIN                    |
| 5. TERMINALS FOR STATOR LEADS |                                 |

**Figure 8. Inside Rear Housing**



## General Check and Adjustment

There are no adjustments for the alternator or most regulators. One Delco alternator and the Leece-Neville alternator has a voltage adjustment.

Always check the general condition of the complete system before doing a complete check on each part. Check the general condition of the following parts: (1) battery, (2) battery cables and connections, and (3) alternator and regulator wires and connectors. Also check the condition and tension of the fan belt for the alternator.



### CAUTION

**NEVER operate the engine if the alternator output BAT terminal is not connected to the battery.**

**Do not short-circuit or connect jumper wires to any of the alternator terminals unless told to by the procedures.**

**Make sure polarity is correct before connecting a battery charger or another battery.**

Remove the battery cables and clean the terminals and cable connectors. Inspect the insulation on the wires. Make sure all the fasteners and connections are clean and tight. If necessary, use a water and soda solution to clean the top of the battery. Do NOT remove the cell caps or permit the water and soda solution to get in the battery.



### WARNING

**Put the transmission in NEUTRAL. Apply the parking brake.**



### CAUTION

**Do not change the polarity of the circuits. Do not connect any wires in the circuits, except as described in these instructions. Never connect the wire from the terminal marked "BAT" to an open circuit.**

When connecting a charger or another battery, connect the positive terminals to the positive terminal of the battery. Then connect the negative terminal to a clean metal part of the engine. Disconnect the charger or other battery in the reverse order. Problems in the charging circuit are indicated by one or more of the following:

- The starter motor turns slowly. The battery voltage is low because of low alternator output or a bad battery.
- The specific gravity readings are low. Battery is not fully charged or is damaged.
- The battery uses more than 30 ml (1 oz) of water per cell per month. The alternator output is too high.

The two problems of the charging circuit are low output and high output. Low output causes a low battery and difficult starting. A high output causes heating of the battery and evaporation of water from the electrolyte. The following two checks will find out if the alternator, regulator, or wiring has a charging fault. The two checks will also find out if the charging system has a correct output. Do the following two checks before removal, disassembly, or replacement of alternator or regulator.

**NOTE:** Information on alternators manufactured outside the United States is in the SRM (service repair manual) sections for lift trucks that use those alternators.

## Low Output Check (Type A or Type B)



### CAUTION

**Do not connect the wire from the "BAT" terminal to the electrical ground.**

**NOTE:** Make sure the wire from the voltmeter makes contact with each terminal on the alternator.

1. Connect a voltmeter between the BAT terminal and the electrical ground. Turn the key switch to the **ON** position and check the reading.
2. Connect a voltmeter to the field terminal and the regulator terminal. Follow the procedure in Step 1 and check the readings.
3. If there are no readings on the voltmeter during Step 1 and Step 2, check for an open circuit between each terminal and the battery.
4. If there are readings on the voltmeter during Step 1 and Step 2, disconnect the cable for the electrical ground on the battery.

5. Make connections to the Type A alternator as shown in Figure 9. Make connections to the Type B alternator as shown in Figure 10.
6. Connect the cable for the electrical ground on the battery.
7. Connect a carbon pile across the terminals of the battery.
8. Run the engine at 2000 to 2500 rpm. Adjust the carbon pile until the maximum charging rate is reached.
9. Read the value of the maximum charging rate shown on the alternator housing or in the section **Capacities and Specifications** for your lift truck. Read the ammeter. The reading on the ammeter must be within 10% of the maximum value.

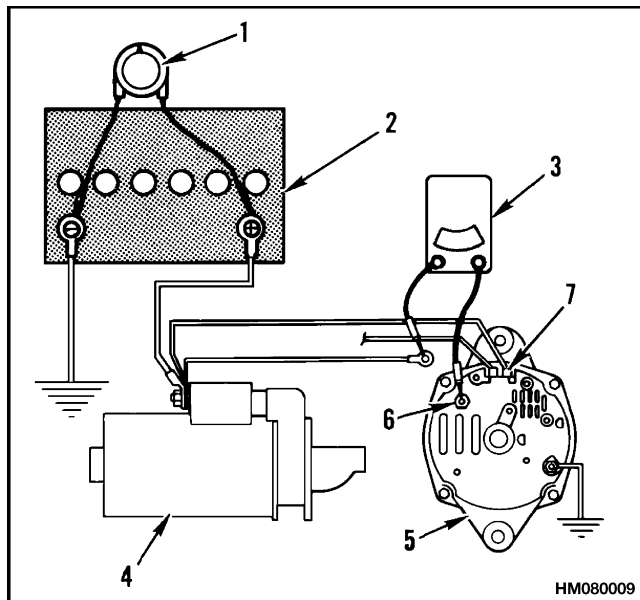

**NOTE:** TYPE A ONLY.

- |                |                   |
|----------------|-------------------|
| 1. CARBON PILE | 5. ALTERNATOR     |
| 2. BATTERY     | 6. BAT TERMINAL   |
| 3. AMMETER     | 7. FIELD TERMINAL |
| 4. STARTER     |                   |

**Figure 9. Alternator Output Check**

10. If the ammeter reading is within 10%, the alternator is in good condition. Check the starter or wires for problems. Some alternators on larger lift trucks have a voltage adjustment. See Figure 12. For alternators with the voltage adjustment, do Step a to set the voltage:
  - a. The voltage setting can be increased by changing the position of the adjustment plug. LO is the lowest voltage setting. 2 is medium low and 3 is the medium setting. The voltage setting is highest when HI is aligned with the arrow on the alternator. Change the setting as necessary.

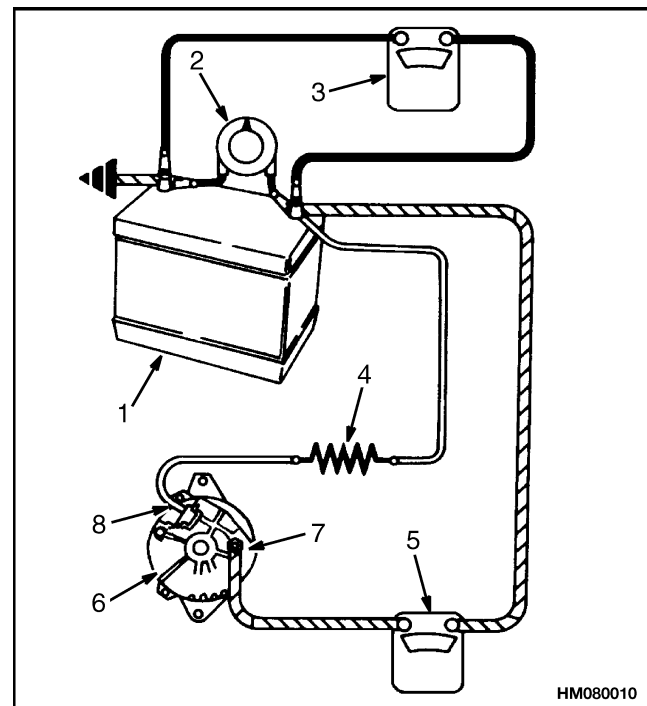

**NOTE:** TYPE B ONLY.

- |   |                          |
|---|--------------------------|
| 1. BATTERY                                      | 5. AMMETER               |
| 2. CARBON PILE                                  | 6. ALTERNATOR            |
| 3. VOLTMETER                                    | 7. BAT TERMINAL          |
| 4. RESISTOR (35 OHM 5 WATT TO 500 OHM 1/2 WATT) | 8. CONNECT TO L TERMINAL |

**Figure 10. Alternator Output Check**

11. On Type A Delco alternators, do the following checks:



### CAUTION

Do not push the screwdriver into the hole for more than 25 mm (1 in.).

- a. If the output shown is not within 10%, put a screwdriver into the hole shown in Figure 11.
- b. Run the engine at 2000 to 2500 rpm. Adjust the carbon pile until the maximum charging rate is reached.
- c. If the output is within 10%, check the field winding. If the field winding is in good condition, replace the voltage regulator.
- d. If the output is not within 10%, check the wires to the brushes, diodes, diode bridge, field winding, and stator.
- e. Remove the screwdriver, ammeter, and variable resistor.

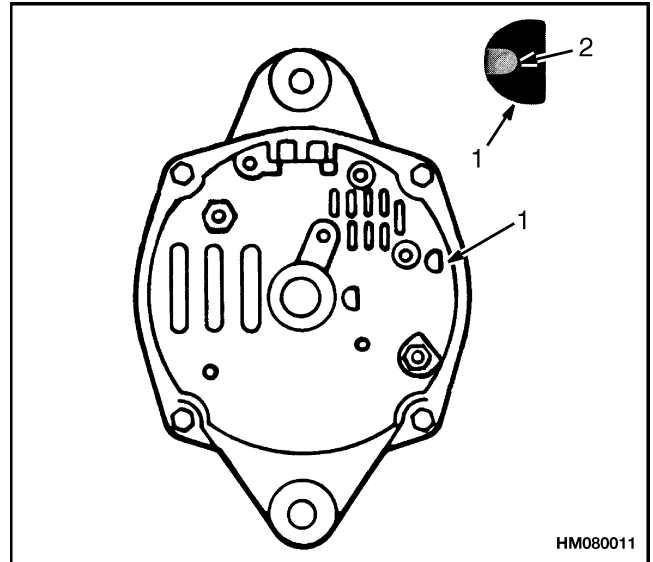

**NOTE:** DELCO TYPE A SHOWN.

1. HOLE
2. MAKE SURE SCREWDRIVER TOUCHES HOUSING AND METAL TAG.

*Figure 11. Electrical Ground on Field Winding*

## High Output Check (Type A or Type B)

1. Connect a voltmeter from the regulator terminal to the electrical ground. Check the reading on the voltmeter. See Figure 9 or Figure 10.
2. If there are no readings, check for an open circuit between the regulator terminal and the battery.
3. If there is a reading, connect a voltmeter between the BAT terminal and the electrical ground.
4. Increase the engine speed until the maximum voltage reading is reached.
5. If the voltage shown is more than 15.5 volts on a 12-volt system or 31 volts on a 24-volt system, disassemble the alternator and do the remainder of the checks. For alternators with the voltage adjustment, do the following:
  - a. Delco alternator. The voltage setting can be increased or decreased by changing the position of the adjustment plug. See Figure 12. LO is the lowest voltage setting. 2 is medium low and 3 is the medium setting. The voltage setting is highest when HI is aligned with the arrow on the alternator. Do not change the setting when engine is operating. Change the setting as necessary.
  - b. Leece-Neville alternator. Remove the screw in the cover. See Figure 12. Start the engine. Connect a voltmeter across the battery terminals and use a screwdriver to adjust the voltage.